

# 12000 CHASE SAVER II<sup>®</sup>

## INSTALLATION INSTRUCTIONS

### SYPHON JET INSTALLATION

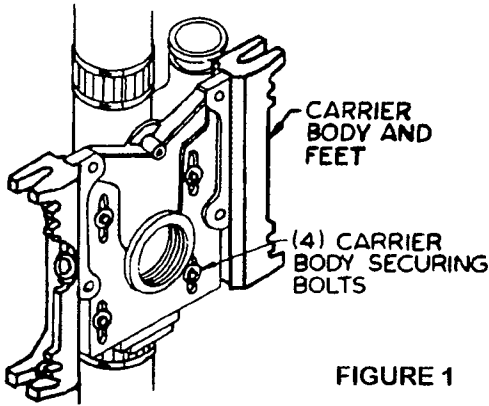

FIGURE 1

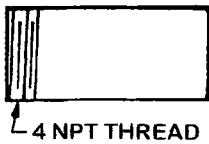

FIGURE 2A



FIGURE 2B

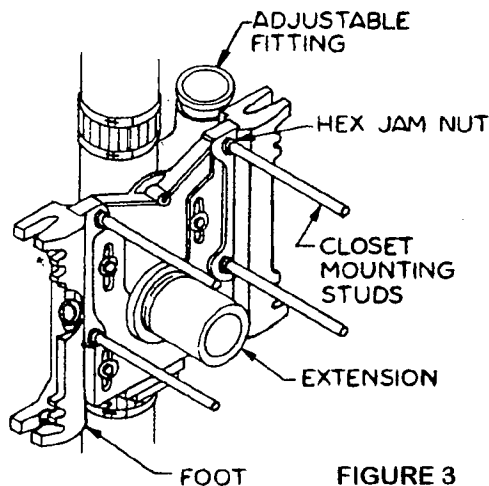

FIGURE 3

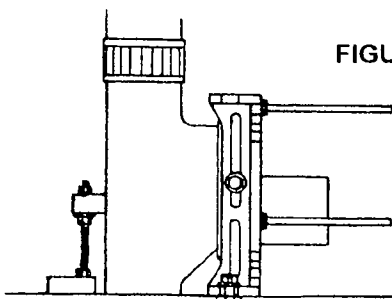

FIGURE 4

ANCHOR FOOT ASSEMBLY

1. Install fitting assembly in waste line to required pitch. Place carrier body in siphon jet position and adjust it to the required roughing. Align oval fitting gasket with inlet opening in fitting and clamp it between fitting and carrier body with the four carrier body securing cap screws. Tighten all cap screws uniformly to a torque between 20 and 25 foot pounds. See Figure 1.

2. a. For extensions used with the 12000-PF carrier body [Figure 2A]: Apply thread sealant to threads on extension. Screw extension into carrier body and tighten. After testing system, mark extension and cut off excess length. Be sure to make cut square. The distance extension should protrude beyond finished wall is defined in 2.c. below.

b. For extensions used with the 12000-OR carrier body [Figure 2B]: Verify that o-ring is properly located in carrier body o-ring groove. Apply thread lubricant to threads on extension and to female threads and o-ring in carrier body. Screw extension into carrier body and adjust to proper position relative to the finished wall. After testing system, carefully remove knockout barrier while maintaining proper position relative to finished wall. The distance extension should protrude beyond finished wall is defined in 2.c. below.

c. Use the following formula for fixtures having a rectangular cross section outlet gasket groove:  $C = A + B - 1/2$  in.

where A = distance from the fixture to the wall

B = depth of the groove in the fixture

C = distance extension protrudes from wall

Use the following formula for fixtures having a V-shaped outlet gasket groove:  $C = A + B - 3/8$  in.

3. Remove 5/8 in. fixture mounting studs from Hardware Group CE. Assemble studs to carrier and adjust them to extend 5/8 in. plus fixture flange thickness beyond finished wall. Lock studs in place with hex jam nuts. Place thread protectors on all studs. See Figure 3.

4. Assemble anchor foot support. Attach all feet to floor with 1/2 in. cap screws provided by others. See Figure 4.

5. Complete construction around carrier.

6. Remove nuts and washers from Hardware Group FH. Place a hex nut, backup washer and bowl stabilizer on each mounting stud. Adjust these parts with front of backup washer at surface of finished wall. See Figure 5.

7. Place fixture outlet gasket into fixture outlet gasket groove and hang fixture. Assemble fiber washers and Josam cap nuts to the two studs on the center line of the fixture outlet and on one other stud. Tighten with wrench. Assemble fiber washer and Josam cap nut to remaining top stud. Hand-tighten and then tighten an additional 1/2 turn with wrench. See Figure 5.

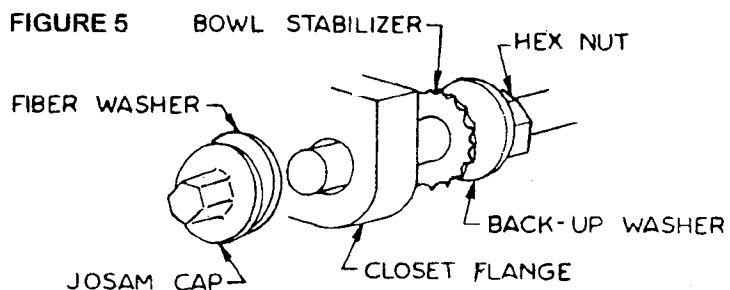

FIGURE 5

# 12000 CHASE SAVER II<sup>®</sup>

## INSTALLATION INSTRUCTIONS

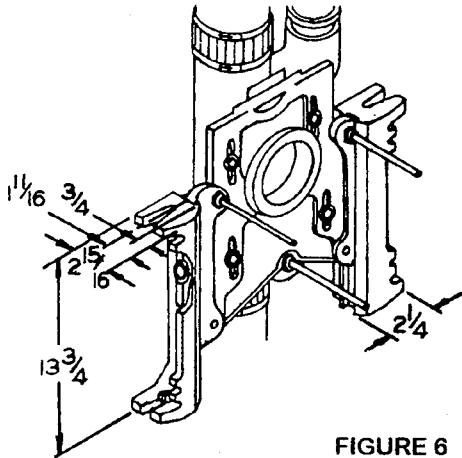

FIGURE 6

### BLOWOUT INSTALLATION

1. Install fitting assembly in waste line to required pitch. Place carrier body in blowout position and adjust it to the required roughing. Align oval fitting gasket with inlet opening in fitting and clamp it between fitting and carrier body with the four carrier body securing cap screws. Tighten all cap screws uniformly to a torque between 20 and 25 foot pounds. See Figure 6.

USE ONLY THE UPPER 2 IN. OF FITTING ADJUSTMENT.

2. Follow Steps 2. through 7. of the Siphon Jet Installation procedure to complete installation.

# 12000 CHASE SAVER II<sup>®</sup>

## ASSEMBLY

